



Heat generation above break-even from laser-induced fusion in ultra-dense deuterium

Leif Holmlid

Citation: *AIP Advances* **5**, 087129 (2015); doi: 10.1063/1.4928572

View online: <http://dx.doi.org/10.1063/1.4928572>

View Table of Contents: <http://scitation.aip.org/content/aip/journal/adva/5/8?ver=pdfcov>

Published by the *AIP Publishing*

Articles you may be interested in

[Neutron yield enhancement in laser-induced deuterium-deuterium fusion using a novel shaped target](#)
Rev. Sci. Instrum. **86**, 063505 (2015); 10.1063/1.4922912

[Efficient source for the production of ultradense deuterium D\(-1\) for laser-induced fusion \(ICF\)](#)
Rev. Sci. Instrum. **82**, 013503 (2011); 10.1063/1.3514985

[Production of ultradense deuterium: A compact future fusion fuel](#)
Appl. Phys. Lett. **96**, 124103 (2010); 10.1063/1.3371718

[Subignition fusion yields generated by fast heating of compressed deuterium–tritium and break-even scaling](#)
Phys. Plasmas **11**, 3483 (2004); 10.1063/1.1753574

[Nuclear fusion in gases of deuterium clusters heated with a femtosecond laser](#)
Phys. Plasmas **7**, 1993 (2000); 10.1063/1.874020

An advertisement for CISE (Computational Science and Engineering) featuring a bee on a yellow flower. The text 'Cross-pollinate.' is on the left. On the right, there is a small image of a CISE journal cover and the text 'Submit your computational article to CISE.'

Cross-pollinate.

Submit your computational article to CISE.

Heat generation above break-even from laser-induced fusion in ultra-dense deuterium

Leif Holmlid^a

*Atmospheric Science, Department of Chemistry and Molecular Biology,
University of Gothenburg, SE-412 96 Göteborg, Sweden*

(Received 10 June 2015; accepted 30 July 2015; published online 10 August 2015)

Previous results from laser-induced processes in ultra-dense deuterium D(0) give conclusive evidence for ejection of neutral massive particles with energy $> 10 \text{ MeV u}^{-1}$. Such particles can only be formed from nuclear processes like nuclear fusion at the low laser intensity used. Heat generation is of interest for future fusion energy applications and has now been measured by a small copper (Cu) cylinder surrounding the laser target. The temperature rise of the Cu cylinder is measured with an NTC resistor during around 5000 laser shots per measured point. No heating in the apparatus or the gas feed is normally used. The fusion process is suboptimal relative to previously published studies by a factor of around 10. The small neutral particles $H_N(0)$ of ultra-dense hydrogen (size of a few pm) escape with a substantial fraction of the energy. Heat loss to the D_2 gas (at $< 1 \text{ mbar}$ pressure) is measured and compensated for under various conditions. Heat release of a few W is observed, at up to 50% higher energy than the total laser input thus a gain of 1.5. This is uniquely high for the use of deuterium as fusion fuel. With a slightly different setup, a thermal gain of 2 is reached, thus clearly above break-even for all neutronicity values possible. Also including the large kinetic energy which is directly measured for MeV particles leaving through a small opening gives a gain of 2.3. Taking into account the lower efficiency now due to the suboptimal fusion process, previous studies indicate a gain of at least 20 during long periods. © 2015 Author(s). All article content, except where otherwise noted, is licensed under a Creative Commons Attribution 3.0 Unported License. [<http://dx.doi.org/10.1063/1.4928572>]

I. INTRODUCTION

Laser-induced nuclear fusion processes^{1,2} are expected to occur quite easily in ultra-dense deuterium D(0). The theoretical understanding of this material has recently been improved.³ Laser-induced fusion in D(0) using nanosecond and picosecond pulsed lasers has been reported.^{4–10} The reason for the quite facile fusion processes is the high density of D(0), close to 10^{29} cm^{-3} or 140 kg cm^{-3} . This means an energy density of 10^{19} J m^{-3} only from the bonding energy, and an energy density at least 10^3 higher from nuclear fusion. Lipson et al.¹¹ have reported experimental results on very high density hydrogen clusters in voids (Schottky defects) measured by SQUIDS in palladium crystals. The close relation between these hydrogen clusters and D(0) has been pointed out.¹² Theoretical results for the laser intensity needed for break-even¹³ and extrapolations from experimental results on D(0)⁵ indicate that approximately 1 J laser pulses are required for break-even. It was recently reported^{8,9} that break-even has been reached in fusion in D(0) even with 0.2 J laser pulses. The proof of nuclear fusion in the processes published so far lies mainly in the generation of massive particles with energy $> 10 \text{ MeV u}^{-1}$ ^{6,8–10} at the low laser intensity of $< 3 \times 10^{13} \text{ W cm}^{-2}$. Recently, also laser-generated penetrating particle emission has been observed by pulse height analysis.¹⁴ These results give definitive proof of nuclear processes. Here, the goal is extended to give proof also for heat generation around break-even, of direct interest for the

^aEmail holmlid@chem.gu.se



application of nuclear fusion for power generation. The results also show that laser-induced fusion is easier to use with other fuels than the normal D-T ice which appears to give compression instabilities even when using MJ laser pulses.^{15,16} Note that in the following H means all isotopes of hydrogen, with p, D and T used explicitly only when needed.

The nuclear processes taking place in the D(0) material are probably not only ordinary D+D fusion. However, the typical ^4He and ^3He particle emissions from the processes have been reported¹⁷ together with a neutron signal with a temperature of 80-600 MK (7-60 keV). Thus, this point will not be discussed further here. The initiation of the fusion processes in D(0) is not due to laser heating to high temperature which has been shown to be inconvenient.^{16,18} Instead, the process is a laser-induced transfer to the spin state $s = 1$ which has a d-d distance of only 0.56 pm.³ From this distance, fusion is spontaneous. This type of process is described more in detail in Ref. 19.

One hoped-for advantage of laser-induced fusion is that the reactor may be relatively small with little influence on the environment. In the most often considered form of nuclear fusion D+T, the neutronicity thus the energy fraction carried away by the neutrons is 0.80.²⁰ This means that 80% of the energy released is difficult to contain and use since it leaves the reactor with the neutrons, if the reactor is not large enough (several m) to retain the neutron energy. This means that small reactors are not possible, also from a radiation protection point of view. For this reason, aneutronic fusion reactions like $\text{D} + ^3\text{He}$ are preferable, since only charged particles $\text{p} + ^4\text{He}$ are produced. The high neutronicity of D+T means that only a small fraction of the energy generated can be used for electric power generation in a small fusion reactor, maybe only $0.3 \times 0.2 = 6\%$, assuming a thermal efficiency of 0.3 for converting heat to electricity which is normal for nuclear power plants. The fusion process D+D used here is better in principle, easily shown to have a neutronicity of 0.66 (values from Ref. 20) since ^3He is assumed not to react efficiently at the low reactor plasma temperature while T reacts on rapidly with D to form $\text{n} + ^4\text{He}$. This is supported by TOF-MS laser-driven fusion experiments in the same system, where ^3He is observed but not T.¹⁷ This means that a maximum of 34% of the energy released may be retained in the apparatus in the present experiments. If also ^3He reacts with D at high enough temperature, the neutronicity of D+D is only 0.34, leaving 66% of the energy in charged particles.²⁰ Of course, some radiation losses (for example bremsstrahlung in the reactor walls) may occur from the charged products, making it difficult to use (or even measure) all the energy in the charged fusion products.

This shows also that only a fraction of the fusion energy will be retained in any reasonably small experimental apparatus. We thus need to consider what is indeed measurable in the present experiments. Let us first assume that the entire laser pulse-energy Q entering the apparatus is used to initiate the fusion process thus is not observed as thermal energy. If the fusion gain is $= 1$ thus as much fusion energy is produced as the incoming laser energy, the thermal energy observed will be only $0.34Q$ due to the loss of the neutrons. To reach a thermal energy of Q in this case means that a gain of around 3 is required. But such a result is not reliable since it may just correspond to the laser energy. To generate a thermal energy of $2Q$, which cannot be mistaken for laser energy, a gain of around 6 is needed. If only 10% of the laser pulse-energy induces fusion, a gain of around 30 is required to give $2Q$. Thus, an observable heat release of $2Q$ by the fusion process in the present experiments requires either (1) a gain of at least 6, more likely $\gg 10$ in the fusion process, or (2) a fusion process with a smaller neutronicity than 0.66. Some experimental facts specific to the ultra-dense deuterium fuel made a test of the heat release in the laser-induced fusion process feasible and worth the effort. These were (1) the gain to kinetic energy of MeV particles was found to be >300 for short periods of time in the experiments,⁸⁻¹⁰ and (2) the flux of neutrons from the process was observed to be small by several different measurement methods,¹⁰ thus the neutronicity appeared to be low. However, neutrons at very high energy >20 MeV would avoid detection. Thus a positive outcome of the experiments seemed likely. This analysis also shows that a heat generation of $2Q$ means a fusion process safely above break-even for all possible neutronicities.

II. DESIGN

The main heat accumulating device needs to be a thick metal part, to stop and retain as many particles of various types as possible. Tests with a thin metal shield were unsuccessful. Due to the

relatively small size of the existing chamber (with 100 mm tube diameter) and the need for gas transport in and around the laser target and the metal part, a cylindrical form with 2 cm wall thickness was chosen. This thickness stops only a few percent of 1 MeV neutrons and much less of the 3 and 14 MeV neutrons generated by an ordinary D+D fusion process. It will stop deuterons, protons and alpha particles even with many MeV energy, for example protons with < 100 MeV.²¹ It will also stop electrons with energy < 10 MeV. However, it will not stop gamma rays with > 0.1 MeV energy. Also small neutral fragments of ultra-dense hydrogen $H_N(0)$ with energy > 10 MeV u^{-1} will pass through the metal container.²² To have optimum heat conduction, copper (Cu) was chosen as the cylinder material instead of lead which is a factor of 10 worse than copper with respect to heat conduction.

The temperature of the Cu cylinder is measured using a small NTC (negative temperature coefficient) sensor. It had been observed that the walls of the chamber also increased in temperature during the experiments, thus making the use of thermocouples with their cold junction (or at least a conductor material change) at the vacuum wall unsuitable. The NTC resistor with its 3 mm head diameter was attached in a small hole with depth of a few mm bored into the Cu cylinder, using heat-conductive silicon paste for heat transfer. This mounting hole was on the outer surface of the cylinder, turned away from the incoming laser beam and at $3/4$ of the height of the cylinder. The response of the thermal measurement was very fast relative to the 8 min time for each measurement, and the slight temperature rise after the laser was turned off (due to heat from the source target) after a full 8 min run was included in the total temperature rise. To minimize the heat loss from the Cu cylinder, it was mounted on four silica glass tube legs. At the low pressure of 5×10^{-3} mbar maintained in the chamber with no gas inlet, the temperature of the cylinder decreased very slowly and a temperature higher than that of the chamber wall was observed even after 16 hours on the next day. Laser test runs with no gas admission gave fast temperature response and very small loss of thermal energy. Thus, no correction for heat loss through the gas in the chamber is used at low pressure and temperature close to the ambient. However, in most experiments a D_2 gas pressure of 0.1-1 mbar needs to be used to form $D(0)$, giving large heat loss both to the gas which is pumped away and through the gas to other parts in the vacuum chamber. Corrections are measured during cooling in the experiments and applied to remove the influence of this cooling.

Due to the requirements of no internal heating and efficient energy collection from the laser induced fusion process, simplifications in the previous construction^{19,22} were needed. These simplifications implied degrading the performance, for the sake of correct energy measurements. The main change was the removal of the target structure, thus removing the possibility to store ultra-dense deuterium for subsequent laser probing at higher densities, as used previously. Instead, a simplified source (just a steel tube) was augmented with a small holder for a piece of Ir metal at its end. D_2 gas was leaked in through the tube, passing over catalyst pieces located inside the tube, and reaching the Ir metal piece which acted as a target at the laser focus in the center of the Cu cylinder. See Fig. 1. This design means that the visible plasma formed was much smaller than in previous experiments.^{7,19,22} However, the variation in plasma intensity with laser focus position on the Ir piece was relatively small, simplifying the needed temperature rise measurements lasting 8-10 minutes for each point. It is worth noting that this situation is far from the expected use for energy generation, where one-shot conditions may be assumed to be chosen. Here, the average over 4800 - 6000 laser shots during 8-10 minutes is observed, thus under very different conditions than in likely future energy producing applications.

The laser-induced processes in $D(0)$ and their energy release are studied here. The term break-even is here meant to indicate that the measured thermal power from nuclear fusion is equally large as the laser power introduced into the apparatus. This laser power is the one measured thermally with two different methods in the experiments, without any probe and with an inert probe. These procedures used are described in detail below. Since the thermal power from fusion is not easily separated from that from the adsorbed laser radiation and since the neutron energy is not explicitly mentioned, this definition is not sufficient. Here, the analysis in the Introduction is used instead, which certifies that conditions well above break-even are reached at an output thermal power twice as large as the laser power.

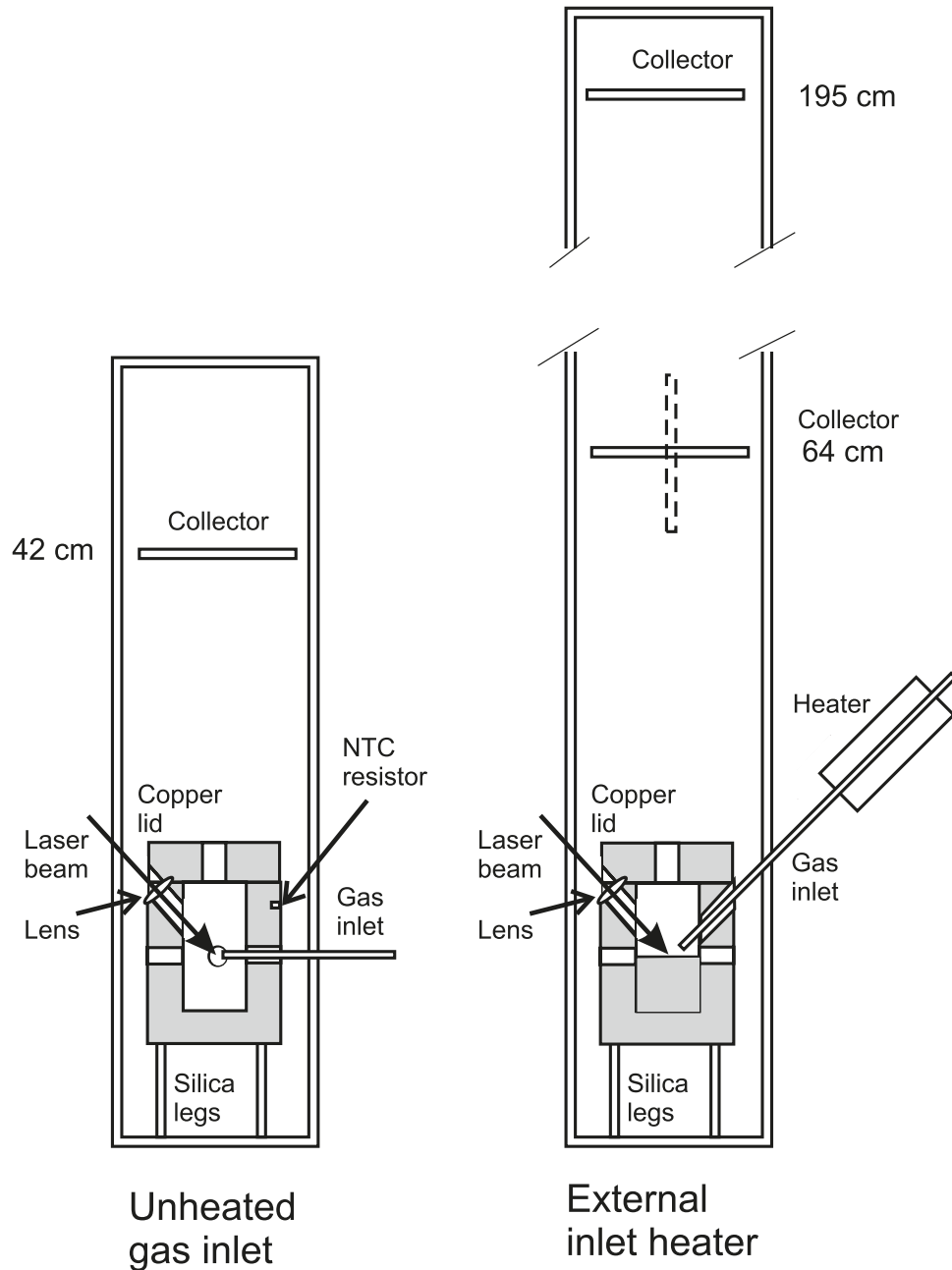

FIG. 1. Principle of the copper (Cu) cylinder setup. The temperature is read from the resistance of an NTC resistor fastened to the outer surface of the Cu cylinder as shown in the left-hand figure. The chamber is pumped continuously at the deuterium pressure of ≤ 1.0 mbar. No heat (left figure) is used in most experiments, while the highest gain is found for the construction to the right where $D(0)$ from a slightly heated source is collected on the Cu surface.

III. EXPERIMENTAL

The layout of the basic experimental setup is shown to the left in Fig. 1. A Nd:YAG laser with nominal pulse energy of < 0.4 J at the laser was employed, with 5 ns pulses at 1064 nm and normally 10 Hz repetition rate. The laser was used at 1064 nm to maintain a more constant energy calibration, not depending strongly on the tuning of the frequency doubling crystal used to give 532 nm light. Further, 1064 nm light seems to give less reflection than 532 nm from the Cu surfaces, thus improving the thermal calibration of the setup. The laser beam was normally focused

with an $f = 40$ mm lens onto the end of the simple tube source. The laser beam waist (focus) is calculated to be < 20 μm for a Gaussian beam at this focal length. This means a laser intensity of $< 3 \times 10^{13}$ W cm^{-2} . A piece of Ir metal in cylinder form (3.5 mm diameter) at the opening of the gas feed tube was in the laser focus. Inside the tube, a few potassium doped iron oxide catalyst samples^{23,24} form ultra-dense deuterium from deuterium gas (99.8%). The ultra-dense deuterium is partially absorbed by the Ir, but finally falls down to the internal bottom of the Cu cylinder. The D_2 gas pressure used in the chamber is ≤ 1.0 mbar with constant pumping (uncorrected Pirani meter reading) using a variable leak valve at $< 10^{-2}$ $\text{mbar dm}^3 \text{ s}^{-1}$. The Cu cylinder has a mass of 3.2 kg. The gas feed tube with its Ir piece at the end is the only part inside the copper cylinder. The NTC resistor (negative temperature coefficient resistor) which measures the temperature of the cylinder is mounted on the outside of the cylinder as shown in Fig. 1. It has a resistance of 6800 Ω at 25 $^\circ\text{C}$ and a temperature coefficient of $-4.38\%/K$ at the same temperature according to the manufacturer. The measurement procedure used here does not rely on these data since the results are relative to the laser power measurements (no probe, inert probe) and span a considerable range in temperature with consistent results.

In some experiments with higher gain, the design to the right in Fig. 1 is used. In this case, an external heater increased the temperature of the catalyst to 30-40 $^\circ\text{C}$. This removes water and other gas molecules from the catalysts, giving a more active catalyst surface. The D_2 gas temperature may also be increased slightly, but it was unobservable as heat to the Cu cylinder due to the small gas flow of the order of 10^{-2} $\text{mbar dm}^3 \text{ s}^{-1}$. The main improvement with this construction relative to that to the left in Fig. 1 is that the $\text{D}(0)$ is collected on the Cu surface. A larger amount of the laser and fusion power may also be absorbed by the Cu target, but stronger plasma reflection is also likely (see further below). The mass of the Cu absorber in this case was increased to 3.5 kg.

The laser-induced process is monitored by the signal at a collector located above the Cu cylinder in the chamber, normally at 42 cm distance from the laser focus. The collector is either Al plate or Al foil on a stainless steel plate frame. The position of the laser focus on the source-target opening is optimized by observing the size and timing of this signal. This certifies that similar conditions for the fusion process prevail during the experiments. The laser removes the fused $\text{D}(0)$ layer and also certainly erodes the target due to the high plasma temperature. The signal is probably mainly due to particles $\text{H}_N(0)$ ^{3,4,25} passing out through the 20 mm wide opening in the top of the Cu cylinder. The collector is connected directly to an oscilloscope via a short 50 Ω coaxial cable. The impedance of the oscilloscope input is 50 Ω . A shielded -50 V battery is normally inserted into the signal path at the feed-through in the vacuum wall to give positive signal voltage on the collector, still giving a 50 Ω connection to the oscilloscope. The oscilloscope used is a fast digital 2-channel oscilloscope (Tektronix TDS 3032, 300 MHz, rise-time 1.7 ns). A 50 Ω RF attenuator is normally used to give a factor of three (-10 dB) lower signal at the oscilloscope. The time-of-flight timing error is shown to be 3-5 ns.¹⁹ Another method to monitor the laser fusion process is by the signal from a fast photo-diode on the outside of the steel chamber wall. This diode is covered completely by black plastic tape, and the large signal output created in it from the laser pulse is due to the plasma current formed inside the chamber, giving strong HF radiation picked up by the diode. Maximum oscillatory signal is found when the MeV particle signal is maximum.

IV. RESULTS

The experimentally observed temperature increase indicated by the NTC resistor during a period of 8-10 minutes was recorded to determine the rate of temperature rise in the experiments. An example showing the data recorded for one data point is shown in Table I. Such a relatively long time is needed to increase the precision in the power measurements and to include the slow flow of heat from the target to the cylinder. The temperature rise is transformed to thermal power using the mass of the Cu cylinder (3.2 kg) and the heat capacity of copper ($425 \text{ J kg}^{-1} \text{ K}^{-1}$). A correction is made for an isotropic loss of particles and light through the six small openings in the Cu cylinder, five of them shown in Fig. 1. The power measured by the Cu cylinder is increased by approximately 11% due to this loss, using the angular opening size as seen from the source target. No other effects like reflections inside the cylinder or laser light losses in the lens are included or compensated for.

TABLE I. Typical NTC results with nominal laser pulse-energy of 380 mJ, 10 Hz, 0.2 mbar D₂ gas. The heating was derived as 2.4 W and the cooling correction was afterwards measured to be 0.3 W, thus total 2.7 W.

Time	NTC on cylinder (kΩ)	Cylinder temperature (°C)	NTC on chamber wall (kΩ)
13:53	7.59	22.66	7.87
13:55	7.52	22.87	7.85
13:57	7.46	23.05	7.86
13:59	7.39	23.26	7.86
14:01	7.32	23.46	7.83
14:03	7.26	23.64	7.81

The heat loss from the cylinder to the gas is measured with the laser off, at the same D₂ pressure and temperature interval during cooling. Normally, this is made directly after the laser experiment with unchanged conditions otherwise. The power loss values vary considerably with other parameters like gas pressure and temperature range. Further test experiments to test the procedure have also been performed. For this cooling power measurement, no correction for the openings in the Cu cylinder is used. This heat loss is compensated for, adding the power lost to give the final thermal power of the experimental point.

There are several further factors which should be considered in the overall experimental evaluation, but where no corrections have been made:

- (1) The laser interaction with the source tip gives reflections of the laser light. This could be counted as a loss thus giving lower heat release than if no reflections took place. This effect is difficult to estimate and it will e.g. vary with the shape (erosion state) of the Ir tip. No direct correction is applied, but tests described below give a measure of this effect.
- (2) Part of the heat released by massive charged particles like deuterons and alphas will stay in the source tip. This gives a heating of the tip and the source tube, which will not be directly observed as a heating of the Cu cylinder. This heat will partially radiate to the Cu cylinder but the cooling process will be quite slow and much of this heat will not be observed during the temperature rise measurements. After the laser is turned off, the temperature of the cylinder is observed to increase slightly due to this effect.
- (3) The hot source (target) is cooled by the flowing D₂ gas, giving an excess gas temperature at the cylinder. This will delay the cooling of the cylinder with the laser off and in this way give a lower heat loss without laser, and a smaller correction than the true one for the heat loss to the gas.

These three effects all give a smaller measured heat due to the laser than the true one. However, they cannot be easily compensated for which means that the results obtained are lower limits to the true power release. The calibration measurements with an inert target (see below) give further information about the effect (1) described above.

A. MeV particle ejection

Typical result of the time-of-flight signal to the collector above the cylinder is shown in Fig. 2. Both positive, negative and zero bias signals are shown there. With negative bias, the secondary electrons from the collector, released by the impact of fast massive particle H_N(0)^{6,8-10} give the signal, observed as a positive signal to the collector. With positive bias, mainly electrons from the surrounding structure, ejected by the impact of similar particles are observed to flow to the collector. With zero bias, only high energy electrons from the collector like Compton electrons and high energy photoelectrons¹⁹ are observed to give a positive current. Note that the peak signal is of the order of 200 mA at a flight time of 30 ns, thus at a particle velocity of 2×10^7 m s⁻¹ corresponding to an energy of 2 MeV u⁻¹. A distribution with negative bias is analyzed further in Fig. 3. The distribution is close to thermal at an energy of 2.5 MeV u⁻¹. For a better interpretation of the almost thermal distribution, see Ref. 26. The MeV particles are not deflected by an applied magnetic field

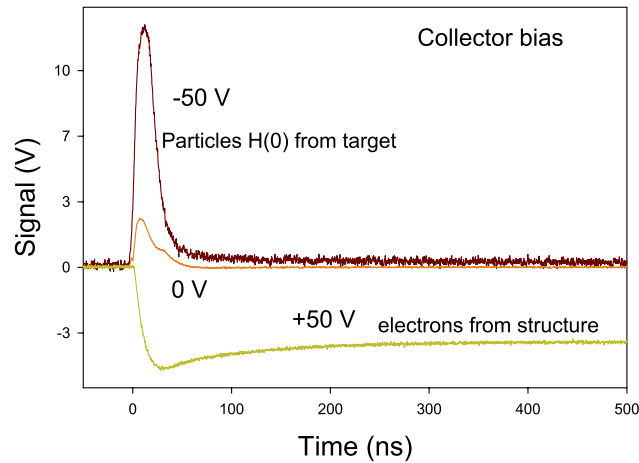

FIG. 2. Time-of-flight signal at the collector in Fig. 1 at 42 cm distance. The bias of the collector is indicated for the three oscilloscope traces.

(up to 0.4 T internal field in the chamber) as they would be if they were electrons.^{19,22} In agreement with other studies,^{6,8–10} these particles are concluded to be neutral fragment (clusters) of ultra-dense hydrogen $H_N(0)$ or particles produced from them. The peak signal in Fig. 3 is 240 mA at a distance of 42 cm and corresponds to 12 mJ of kinetic energy per laser pulse or a power of 0.12 W assuming proton masses. This kinetic energy is found directly from the signal current TOF distribution of the MeV particles. If these particles are heavier than protons, their energy is correspondingly larger, and conversely.

The signal to the collector gives information about the efficiency of the fusion process also relative to previous measurements. An example of the charge generation by impinging quanta and particles at a collector at 42 cm distance from the laser focus is shown in Fig. 4. The charge generated is integrated for 500 ns to give each point in the diagram, thus only the fast particles are included. The signals found are quite normal in their time variation thus similar to Refs. 19 and 22, but the signal level found here is at least a factor of 10 lower than in experiments using the standard source and target construction in the apparatus. This is due to the smaller plasma caused by the non-optimum source and target used here. As shown below, the results here indicate a gain of 1.5, thus with the previously used, optimized construction the gain would be approximately $10 \times 1.5 = 15$ or giving up to 4 J per laser pulse. This conclusion does not rely on any basic assumption about an isotropic angular distribution of the ejected particles which was used previously.^{8,9}

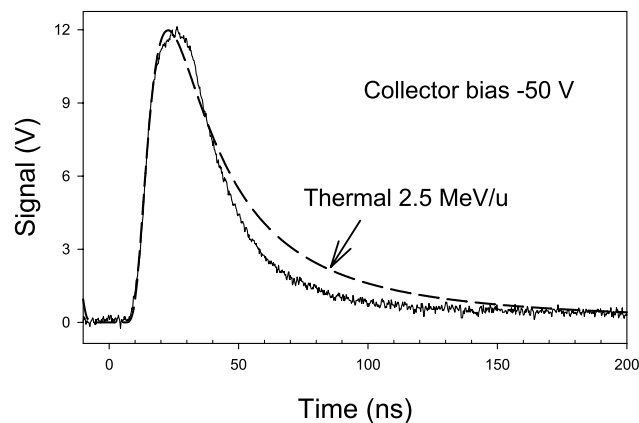

FIG. 3. Typical collector signal with bias -50 V and 42 cm distance. The dashed curve is a thermal distribution at 2.5 MeV u^{-1} . The particles directly observed at the collector have a total particle energy of 12 mJ per laser pulse assuming one charge per particle and proton mass.

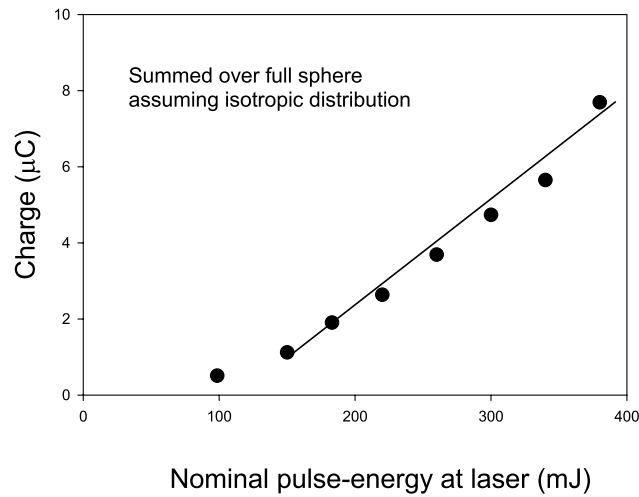

FIG. 4. Total charge generated as calculated from the signal at the collector. The collector at 42 cm distance observed a fraction of 2.3×10^{-3} of the total solid angle around the target. The variation of this total charge with laser pulse-energy (nominal) at 10 Hz repetition, 1064 nm wavelength is shown, assuming isotropic ejection from the laser focus.

B. Thermal power

The calibration of the laser pulse-energy and the response of the thermal measurements is an important point to consider. Two different types of measurements have been done to understand the operation of the system. One is the measurement of the thermal power delivered by the laser alone, with no laser target at all. The same measurement procedure was used as for the fusion points for the temperature rise during 8-10 min. No gas inlet and no temperature compensation due to heat loss from the Cu cylinder were used. Referring to Fig. 1, this means that the laser beam impacts defocused at the lower corner in the Cu cylinder with no probe in the cylinder. From there, the light is reflected and scattered and finally absorbed in the cylinder to a large part. Due to the geometry, just a small fraction will be able to leave the cylinder through the openings, so no correction is used for such loss. The measured power gives the points marked “Laser power” in Fig. 5. These values are lower than the values used on the other axis, the nominal pulse-energy at the laser. These nominal (optimum) energy values are not the same as the laser-energy absorbed in the cylinder since five dichroic mirrors (not all at designed 45° reflection), one window and one glass lens are

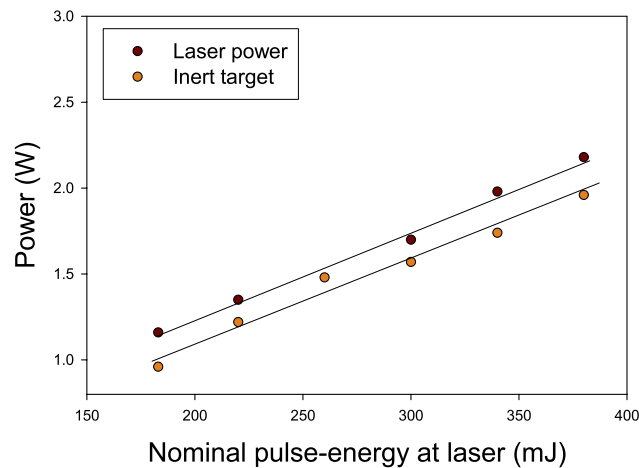

FIG. 5. Calibration values of the power to the Cu cylinder, measured as a temperature rise during 8-10 minutes with laser-pulse energy (nominal at laser) as shown. Laser pulse repetition frequency 10 Hz, laser wavelength 1064 nm.

in the beam from the laser to the cylinder. The lens is always partially covered by sputtered metal from the target. (The laser is neither in perfect operating condition due to the state of the internal flash lamps). Since some of the laser power is normally reflected from the plasma when the laser is focused on the source tip, the laser power values in Fig. 5 may be too high. To get some estimate of the reflections, a PTFE(Teflon)-tipped probe is inserted in the cylinder instead of the Ir probe, with no D_2 gas or catalysts. Thus, no fusion reactions are possible with this probe but a small plasma and reflections from it will exist. The results are given in Fig. 5 as “Inert target”, here using the correction for losses through the openings in the cylinder (11% increase as previously). The two sets of data in Fig. 5 agree quite well. They are both linear, with a small difference of 0.18 W on average possibly due to absence of reflections from the cylinder in the case of the laser power measurement. This 0.18 W difference ($0.18/1.5 = 0.12$ in the middle of Fig. 5) is numerically close to the 11% leaking out through the openings but not in the case with no probe. The linearity of the plots in Fig. 5 shows that the laser intensity is constant and reproducible. It decays during the experiments mainly by the increasing metal coverage on the internal focusing lens, which needs to be changed often. The experiments with an inert target are deemed to give the most reliable laser power values.

A comprehensive set of data with variation in laser pulse-energy, Cu cylinder temperature and gas pressure is shown in Fig. 6. These results are found in experiments during three weeks with no change of the source position, with arbitrary order in time to avoid operational bias due to laser erosion and removal of D(0) from the source tip. The measurements have used many different combinations of laser pulse-energy, initial cylinder temperature, gas pressure and laser focus position on the Ir source tip to test that the method works reliably and reproducibly. See further below about the cooling correction. Prior to this, the laser beam at 532 nm was taken into the chamber to the source Ir tip, with the help of a diode monitor laser which had been correctly pre-aligned into the Cu cylinder. After that, the laser was changed to 1064 nm light with largely unchanged position at the entrance window into the vacuum chamber. Experiments with both beams showed that a plasma was formed at the source tip, so the alignment was concluded to be satisfactory at the source tip and to give a position where the laser beam passed into the chamber largely unobstructed by the entrance tube. After this, the source position was unchanged. The laser focus position on the source tip was optimized by adjusting a mirror just outside the entrance window several times during each 8-10 minutes run giving each point in the diagrams. This optimization brought the TOF signal back close to its initial form and size. This process is required since the laser-induced fusion process removes the D(0) layer on the source, and the diffusion process is not fast enough to maintain the same D(0) layer at high temperature. Optimizing the laser position on the source tip to preserve the same TOF emission picture on the oscilloscope means that the interaction conditions are kept

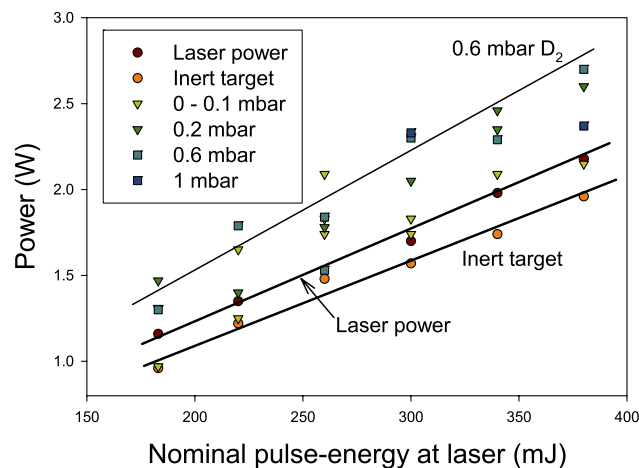

FIG. 6. Power to the copper cylinder measured as a temperature rise during 8-10 minutes with laser-pulse energy (nominal at laser) as shown. Laser pulse repetition frequency 10 Hz, laser wavelength 1064 nm. The deuterium gas pressure in the vacuum chamber is given as parameter.

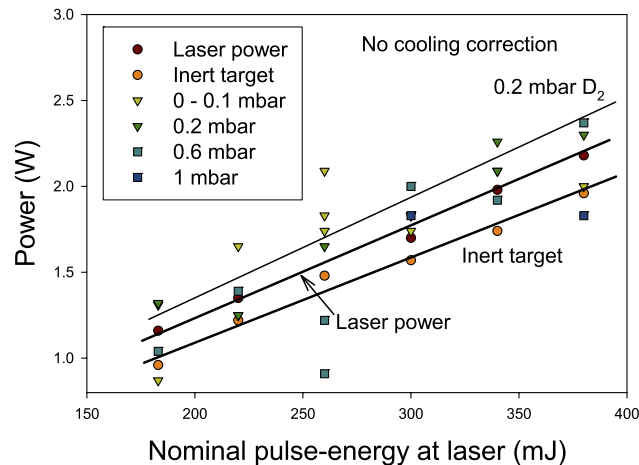

FIG. 7. Power to the copper cylinder measured as a temperature rise during 8-10 minutes with laser-pulse energy (nominal at laser) as shown. Same experiments as in Fig. 6 but no cooling corrections.

as constant as possible, despite the necessary erosive effect of the laser pulses on the surface layer and the target metal on the source. The calibration results from Fig. 5 are also included in Fig. 6. The results agree with those found with low deuterium inlet only at the lowest laser pulse-energies, where fusion is a small effect. This is as expected if the procedure works correctly. The optimum deuterium gas pressure seems to be around 0.6 mbar, since at higher pressures the heat loss to the gas is too large to be easily corrected for.

The cooling by the gas in the chamber was compensated for by measuring the cooling with the same gas pressure and in the same temperature interval, usually directly after each experiment. After a long series of experiments, the temperature of the Cu cylinder was high and the cooling was large, which gives a large correction. The heat loss at 0.6 mbar pressure could be 0.2-0.4 W depending on the temperature of the Cu cylinder relative to ambient. This seems to be the limit that can be treated accurately in this way. To give accurate results, most experiments in Fig. 6 have been done at temperatures not higher than 3 K above the starting ambient temperature. In Fig. 7, the same data as in Fig. 6 are shown with no cooling corrections, thus giving a much larger spread in the values found at each pulse-energy. As can be seen, the cooling corrections give a similar and smaller spread to the results in Fig. 6 at each pulse-energy. Thus, the cooling corrections appear to work also from this point of view. The measurements are performed with several uncontrolled parameters, like the initial cylinder temperature, the temperature of the source tip, the amount of D(0) on the tip, the cleanliness of the catalyst, the damage state of the Ir tip, the temperature of the apparatus wall etc. (Many of these parameters are measured or observed, but they are not directly controlled thus given an arbitrary value or condition repeatedly in the experiments). Despite this, the cooling corrections remove most of the variation at each laser energy point, as seen by comparing Figs. 6 and 7. This means that the other parameters are of less importance and that the method used works to demonstrate the heating due to the fusion process.

During the experiments, the temperature of the chamber (measured on the outside of the vacuum wall) normally increased but was always below that of the Cu cylinder. The temperature increase is smaller later in the day after several experiments (stabilizing slightly above ambient), and thus has an internal source like scattered laser light and impact of neutral particles penetrating through the Cu cylinder. The apparent power to the chamber is of the order of 1-4 W, not including the cooling by the ambient atmosphere.

C. Higher efficiency

With the construction shown to the right in Fig. 1 with collection of the formed D(0) on a Cu target, more rapid heating due to laser-induced fusion is observed. These experiments are included

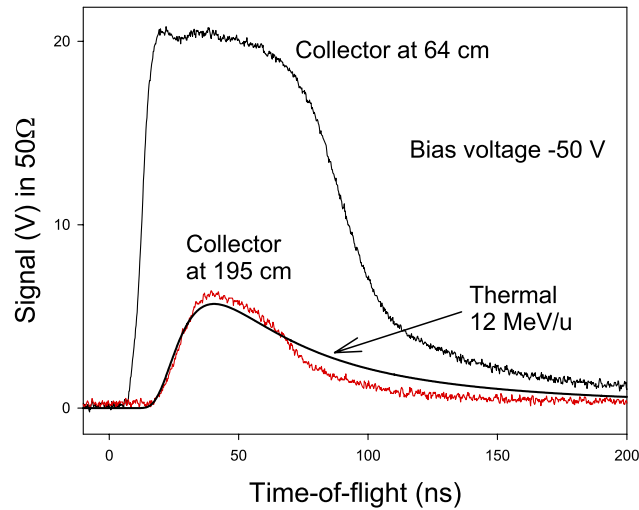

FIG. 8. Signal to the collectors in the set-up to the right in Fig. 1. The total charge to the collector at 64 cm is found directly as 3×10^{-8} As per laser pulse, from a peak current of 400 mA. With an average kinetic energy of 2 MeV u^{-1} , this gives 60 mJ per pulse, or 0.6 W at 10 Hz repetition rate. The collector at 195 cm gives an almost thermal distribution at 12 MeV u^{-1} . Note that the signal at 195 cm is too high and too fast relative to that at 64 cm distance.

here just to prove that such results are indeed possible to find, and a full study of the type summarized in Figs. 6 and 7 was not performed. Using the same method with heat measurement during a few minutes and with compensation for the heat loss to the D_2 gas (at 0.13 W), a power of 3.76 W was found as maximum at the maximum laser power of approximately 1.9 W. This is a gain of 2.0 thus at break-even relative to the total measured laser power into the apparatus, or clearly above break-even from the inclusion of the neutronicity as given in the Introduction. Thus break-even has been reached.

In Fig. 8, the signal at a more distant collector (almost 2 m distance) is also shown, in this case with the collector at 64 cm closed. Thus, the particles observed penetrate through 2 mm of Al, since they are of the form $\text{H}_N(0)$ with typical size of 2 pm. The offset of 10 ns between the rise of the two collector signals proves that the signal is not due to photons but to massive particles. Their maximum velocity was equal to 0.3 of the speed of light. The distribution at the distant collector has a typical energy of 12 MeV u^{-1} , while the signal at short distance has a typical energy of 2 MeV u^{-1} . In the figure, it is very clear that the distribution at long distance ($195/64 = 3.0$ ratio) is much faster than at short distance. This is due to a lifetime of the order of 10-50 ns of the particles giving the signal.²⁶ The peak signal at almost 2 m distance is 100 mA with an energy of 12 MeV u^{-1} , thus a total kinetic energy of 60 mJ or a power to this distant collector of 0.6 W.

V. DISCUSSION

It is difficult to make an experiment of this type with laser-induced fusion without having strong reflection of laser light from the plasma region where fusion takes place. This problem exists also in more complex setups like the NIF.¹⁸ This is so since the plasma at high temperature contains a large density of free charges mainly electrons which will follow the varying electric field due to the laser light field, and in this way partly prevent the light to penetrate into the plasma. This problem is enhanced by a relatively long laser pulse as used here (7 ns), which means that a plasma may be formed even before all of the laser pulse has reached the target. The direct reflection from the target area is modeled here by using an inert surface (PTFE, Teflon) which is known to not support any layer of ultra-dense deuterium on its surface.^{8,25} However, there is no direct reflection of the laser light but only a diffuse scattering which is a bad model of the actual behavior, and only a small plasma is formed at the laser focus on the PTFE probe. Thus, the heat recorded at the Cu cylinder in this type of experiment is still the total impinging laser intensity, minus the fraction lost

through the openings in the Cu cylinder and through heat conduction through the steel arm holding the PTFE target. This "inert target" heat should be easily related to the total heat delivered by the laser-pulses, as also demonstrated in Fig. 5. In the experiments with the total laser energy thus with no probe or target in the Cu cylinder, the laser beam is still focused at the center of the cylinder and hits the lower (bent) corner in the cylinder as an expanding beam with 40 mm focal length. Thus, the reflections and scattering processes inside the cylinder are quite random. The use of the Cu cylinder to measure the laser pulse-energy is a convenient and accurate method constituting an efficient dump for the laser beam energy. It works more reliably than the commercial energy meters used.

The nature of the particles formed is crucial for estimating the power trapping efficiency of the Cu cylinder. The construction chosen gives mainly a mono-layer ignition process, where most of the particles generated are massive in the form of fragments of ultra-dense hydrogen $H_N(0)$. This implies that the energy in the form of gamma and neutron radiation probably will be small. A direct experiment proves this point, by blocking the upper opening in the cylinder with an Al foil. Intermediate-energy gamma photons would pass through this foil but still interact with the collectors used to monitor the fusion process, while neutrons would go undetected. In the experiment described, almost all the collector signal was removed by the foil. This means that the power loss through gamma radiation probably is small with mono-layer ignition.

The possibility of chemical reactions giving the heating can be rejected immediately. If the maximum amount of deuterium leaked into the apparatus burned with oxygen gas (which is not there), the power should be 1.2 W. This value is thus an upper limit to any chemical reaction involving the deuterium gas. The reaction $D_2 + Ir_2$ is likely endothermic (the analogous Pt reaction is endothermic, as also the analogous Fe reaction) and can thus not give any power out. Ir melts at 2680 K and is the second most dense metal, 18% denser than U. Its evaporation enthalpy is very high, at 669 kJ mol^{-1} , so any kind of reaction of Ir is unlikely. A process that however exists in the system is condensation of deuterium to $D(0)$. The condensation processes in $D(0)$ for example from the spin level $s = 2$ to $s = 1^3$ will release a large amount of energy, in a similar way as that proposed for self-compression in $p(0)$ previously.²⁷ However, such transitions are certainly reversible and the time between the laser shots is long enough to re-establish the initial equilibrium. Thus, the energy given off by rearrangements (condensation) would rapidly be required again to reach equilibrium, and a constant energy flux from the system would not be possible during the 8-10 min used for each data point in Fig. 6. This is a further important reason to not use short measurement times or one-shot conditions.

The method used to measure the fusion-generated heat here is found to be reliable. The good agreement between the inert target and laser power results in Figs. 5 and 6 indicates this. The maximum power for each laser pulse-energy gives a gain of 1.45 ± 0.06 in fusion relative to the inert target data on average, thus below break-even which would give 2.0. With a slightly different set-up as in Fig. 1 (right figure) break-even with gain 2.0 is found. Note that the thermal power is related to the total laser power into the apparatus, not to the laser power absorbed by the fuel as used recently in another fusion study.¹⁸ Several factors which are difficult to compensate for decrease the measured power relative to the true power as discussed above, which means that the gain cited is indeed a lower limit.

This discussion has so far only treated the measured heat at the Cu cylinder. However, many particles with high energy are not captured by the Cu cylinder, e.g. fast neutral fragments like $H_N(0)$, neutrons and high-energy gamma photons. This is described above. The fluxes of neutrons and gamma are relatively small (measured with standard instruments) and the total energy carried by such particles is not believed to be large. RF radiation from the fusion process has also been measured but only at low power levels. However, the neutral $H_N(0)$ particles with MeV energies⁸⁻¹⁰ are important. Just a small part of this flux is directly measured here to a distant collector as in Figs. 2-4. For example in Fig. 3, the total energy in the measured particles is 12 mJ per laser pulse or 0.12 W at 10 Hz pulse repetition rate, assuming one charge per mass unit of the particle as in the case of $H_1(0)$. In Fig. 8, similar results are found for the set-up to the right in Fig. 1. In this case, the total power in the directly measured particle signal is 0.6 W with the same conditions. This energy should be included in the total energy release from the fusion process, increasing the gain from 2.0

to 2.3 in this case. Since the collector in Fig. 8 only covered 10^{-3} of the total angular range around the target, the total energy in the fast particles would be 600 W if the distribution is isotropic in 4π . Such particles penetrate through the Cu cylinder to some extent and their angular distributions are not known with certainty. More information is thus needed before including such derived value in the results. However, the directly measured particle energies should be included. It has recently been found that large fluxes of penetrating leptons²⁸ are formed in the experiments.¹⁴ They appear to carry away a large power from the system.

As pointed out above, the signal level to the collector is a factor of approximately 10 lower than in experiments using the standard source and target construction in the apparatus with 1064 nm laser light. This is due to the smaller plasma caused by the non-optimum source used here. This may mean that the gains derived of 1.5 and 2.0 (or 2.3 including particles) in the two different set-ups should be scaled up by a factor of > 10 to give results that are comparable to the previous results.^{8,9,19,22} This would mean a gain of 15-23 with the optimized source, lower than previous results which assumed an isotropic distribution in space. However, much higher signals have been obtained for short periods previously.

Using the neutronicity of 0.66 for the D+D fusion reaction, the thermal gain 1.5 observed corresponds to a real gain of $1.5/0.34 = 4.4$ including the neutrons which should be emitted in this case. This neutronicity in the present type of experiment is supported by the detection of ^3He but not T by TOF-MS in Ref. 17. If the neutronicity of D+D instead is 0.38 which means that not only T but also ^3He reacts with D in the second fusion step, the real gain would be $1.5/0.62 = 2.4$ including the neutrons. See further in the Introduction. However, the number of neutrons detected is small, possibly since they are retained by the very dense D(0) layer.^{5,6,10,17}

VI. CONCLUSIONS

The laser-induced nuclear fusion process in ultra-dense deuterium D(0) gives a heating power at least a factor of 2 larger than the laser power into the apparatus, thus clearly above break-even. This is found with 100-200 mJ laser pulse-energy into the apparatus. No heating is used in the system, to minimize problems with heat transfer and gas transport. This gives sub-optimal conditions, and the number of MeV particles (and thus their energy) created in the fusion process is a factor of 10 below previous more optimized conditions. Several factors lead to lower measured heat than the true value, and the results found are thus lower limits to the real performance. With the optimum source conditions used previously, a gain of 20 is likely also for longer periods.

ACKNOWLEDGEMENT

The construction of the apparatus used here was supported by GU Holding, The Holding Company at University of Gothenburg.

- ¹ R. Kodama, P. A. Norreys, K. Mima, A. E. Dangor, R. G. Evans, H. Fujita, Y. Kitagawa, K. Krushelnick, T. Miyakoshi, N. Miyanaga, T. Norimatsu, S. J. Rose, T. Shozaki, K. Shigemori, A. Sunahara, M. Tampo, K. A. Tanaka, Y. Toyama, T. Yamanaka, and M. Zepf, *Nature* **412**, 798 (2001).
- ² R. Betti, A. A. Solodov, J. A. Delettrez, and C. Zhou, *Phys. Plasmas* **13**, 100703 (2006).
- ³ L. Holmlid, *Int. J. Mass Spectrom.* **352**, 1 (2013).
- ⁴ S. Badiei, P.U. Andersson, and L. Holmlid, *Laser Part. Beams* **28**, 313 (2010).
- ⁵ P.U. Andersson and L. Holmlid, *J. Fusion Energy* **31**, 249 (2012).
- ⁶ L. Holmlid, *Eur. Phys. J. A* **48**, 11 (2012).
- ⁷ F. Olofson, A. Ehn, J. Bood, and L. Holmlid, in *39th EPS Conference on Plasma Physics 2012 (EPS 2012) and the 16th International Congress on Plasma Physics, Europhysics Conference Abstracts*, edited by S. Ratynskaya (Curran Associates, 2013), Vol. 36F, pp. 472-475, ISBN: 9781622769810.
- ⁸ L. Holmlid, *Nucl. Instr. Meth. B* **296**, 66 (2013).
- ⁹ L. Holmlid, *Laser Part. Beams* **31**, 715 (2013).
- ¹⁰ L. Holmlid, *Int. J. Modern Phys. E* **22**, 1350089 (2013).
- ¹¹ A. Lipson, B. J. Heuser, C. Castano, G. Miley, B. Lyakhov, and A. Mitin, *Phys. Rev. B* **72**, 212507 (2005).
- ¹² L. Holmlid, H. Hora, G. Miley, and X. Yang, *Laser Part. Beams* **27**, 529 (2009).
- ¹³ S. A. Slutz and R. A. Vesey, *Phys. Plasmas* **12**, 062702 (2005).
- ¹⁴ L. Holmlid and S. Olafsson, (submitted).
- ¹⁵ V. A. Smalyuk, *Phys. Scr.* **86**, 058204 (2012).

- ¹⁶ L. Holmlid, *J. Fusion Energy* **33**, 348. DOI: 10.1007/s10894-014-9681-x (2014).
- ¹⁷ F. Olofson and L. Holmlid, *Int. J. Mass Spectrom.* **374**, 33. DOI: 10.1016/j.ijms.2014.10.004 (2014).
- ¹⁸ O. A. Hurricane, D. A. Callahan, D. T. Casey, P. M. Celliers, C. Cerjan, E. L. Dewald, T. R. Dittrich, T. Döppner, D. E. Hinkel, L. F. Berzak Hopkins, J. L. Kline, S. Le Pape, T. Ma, A. G. MacPhee, J. L. Milovich, A. Pak, H.-S. Park, P. K. Patel, B. A. Remington, J. D. Salmonson, P. T. Springer, and R. Tommasini, *Nature* **506**, 343. DOI:10.1038/nature13008 (2014).
- ¹⁹ F. Olofson and L. Holmlid, *Int. J. Modern Phys. E* **23**, 1450050. DOI: 10.1142/S0218301314500505 (2014).
- ²⁰ F. Winterberg, *The release of thermonuclear energy by inertial confinement* (World Scientific, 2010).
- ²¹ NIST, Physics Laboratory, PSTAR program, <http://physics.nist.gov/PhysRefData/Star/Text/PSTAR.html>.
- ²² F. Olofson and L. Holmlid, *Laser Part. Beams* **32**, 537. doi:10.1017/S0263034614000494 (2014).
- ²³ G.R. Meima and P.G. Menon, *Appl. Catal. A* **212**, 239 (2001).
- ²⁴ M. Muhler, R. Schlögl, and G. Ertl, *J. Catal.* **138**, 413 (1992).
- ²⁵ F. Olofson and L. Holmlid, *J. Appl. Phys.* **111**, 123502 (2012).
- ²⁶ L. Holmlid, *Int. J. Modern Phys. E* **24**, 1550026. DOI: 10.1142/S0218301315500263 (2015).
- ²⁷ F. Olofson and L. Holmlid, *Nucl. Instr. Meth. B* **278**, 34 (2012).
- ²⁸ W.E. Burcham and M. Jobs, *Nuclear and Particle Physics* (Pearson Education, Harlow, England, 1995).